



D20NX / D25NX / D30NX / D33NX / D35NX
D20NXP / D25NXP / D30NXP / D30NXP / D35NXP

NX SERIES FORKLIFTS

Diesel 2.0 to 3.5 ton Capacity



Everything has been changed. New NX, The Game Changer.

Experience the fully enhanced value of NX Series

The new NX series offering outstanding power, durability and operator comfort realizes customer satisfaction through providing the best productivity and convenience in various industrial applications.

NEW STYLISH DESIGN

- By applying the **Doosan New design**, it represents the Doosan's unique exterior.

POWERFUL PERFORMANCE

- The combination of powerful engine and rigid transaxle provides **25%** of gradeability with loaded.
- With the optimized Doosan hydraulic system, NX has unbeatable travel / lifting speed.



OUTSTANDING DURABILITY

- **New aux weight design** lowers the center of gravity and helps reducing noise, vibration and heat.
- Cooling capacity has increased by optimizing the air flow of engine room and counter weight design.
- Anti dust head guard design and dual element air cleaner extend the service interval and guarantee the durability of engine.
- The mast has higher stiffness, makes operation more stable.

EXCELLENT OPERATOR COMFORT

- Leg room is enlarged by about **30%** than previous model.
- Clearance & angle of accel & brake pedals are improved to decrease fatigue of ankle.
- Compact steering wheel allows quick control and reduces wrist fatigue.
- Mast visibility has improved by rearranging the hoses & chains.
- Front/rear visibility has been increased by improving the design of FCU & Counterweight

Powerful Performance

The combination of powerful engine, transmission, and drive axle maximizes the performance and gives best productivity in various work applications.

Aux Weight

The new aux-weight structure increases the stability of vehicle. The lowered center of gravity enhances lifting capacity at high height racking and gradeability.



◀ NXP Model
Yanmar Diesel Engine
4TNE98(3.3L) /
4TNE94L(3.0L)

This Yanmar 3.0L / 3.3L diesel engine gives high-torque at low RPM, designed for industrial vehicles. It effectively improves acceleration, driving and climbing performance of the forklift truck. It is complied with Euro Stage IIIA or EPA Tier III.

▶ NX Model
Weichai Diesel Engine
WP3.2(3.2L)

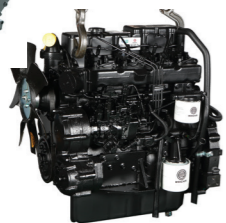

Weichai diesel engine gives high performance. It's optimized torque & RPM ratio gives maximum working performance in climbing and lifting.



Powerful Gradeability

With the powerful engine, transaxle and aux weight structure, gradeability is maximized and makes it easy to go up the 25% steep slopes.

Max Gradeability. (@1.6km/h, Laden, 3.0t capacity truck)



High Residual Capacity

NX can lift about 10% more weight at the same height with the aux weight structure and powerful hydraulic system. It is suitable for work areas with high rack height.



Outstanding Stability

The new aux-weight lowers the center of gravity and enables to lift heavier load. It is suitable for those applications handling heavy load.



High Speed of Lifting / Lowering

Gear pump and mast regulator valve are optimized to increase the lifting / lowering speed and it makes operation more productive.

Durability Guaranteed

The NX Series is equipped with advanced design to reduce noise, vibration, heat, dust - inflow, ensures durability of major components. With the improved design and additional option, NX guarantees durability in harsh operating conditions.

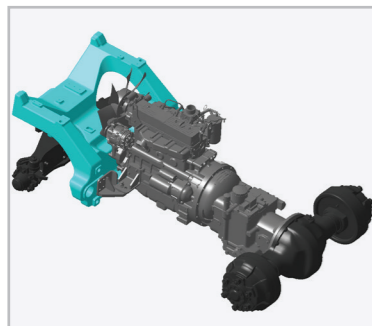

Aux Weight

Many troubles are caused by vibration. In NX series, the engine is mounted on the Aux. weights to effectively absorb vibration and suppress noise. It extends parts durability and prevents durability decline and oil leakage.

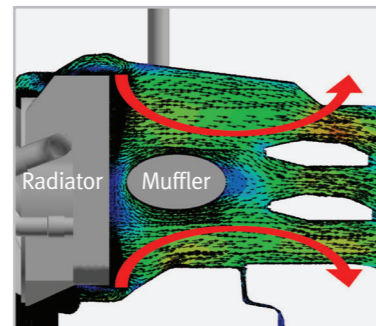

Optimized Air Flow

Air flow is optimized by improving muffler position, clearance between parts and enlarging the inner space of counter weight. It streamlines the air flow and increases the cooling performance.



Robust Mast

Reinforcement rib(j channel) of mast beam improves mast stiffness and lateral stability. Six roller carriage gives superior strength and durability for wider and longer loads.



Anti Dust Design

The bottom-sealed overhead guard absolutely eliminates the dust inflow from the bottom side.



Dual Elements Air Cleaner

Air cleaner with dual element filter protects engine against dust effectively, ensuring the durability of engine. It is equipped as standard in NX Plus model.



Pre Cleaner (Option)

In a dusty environment, pre-cleaner removes dust in advance and extends lifecycle of air cleaner effectively.

Excellent Operator Comfort

The operator compartment is more spacious and ergonomically designed to reduce driver's fatigue. It enables more comfort and safe operation.

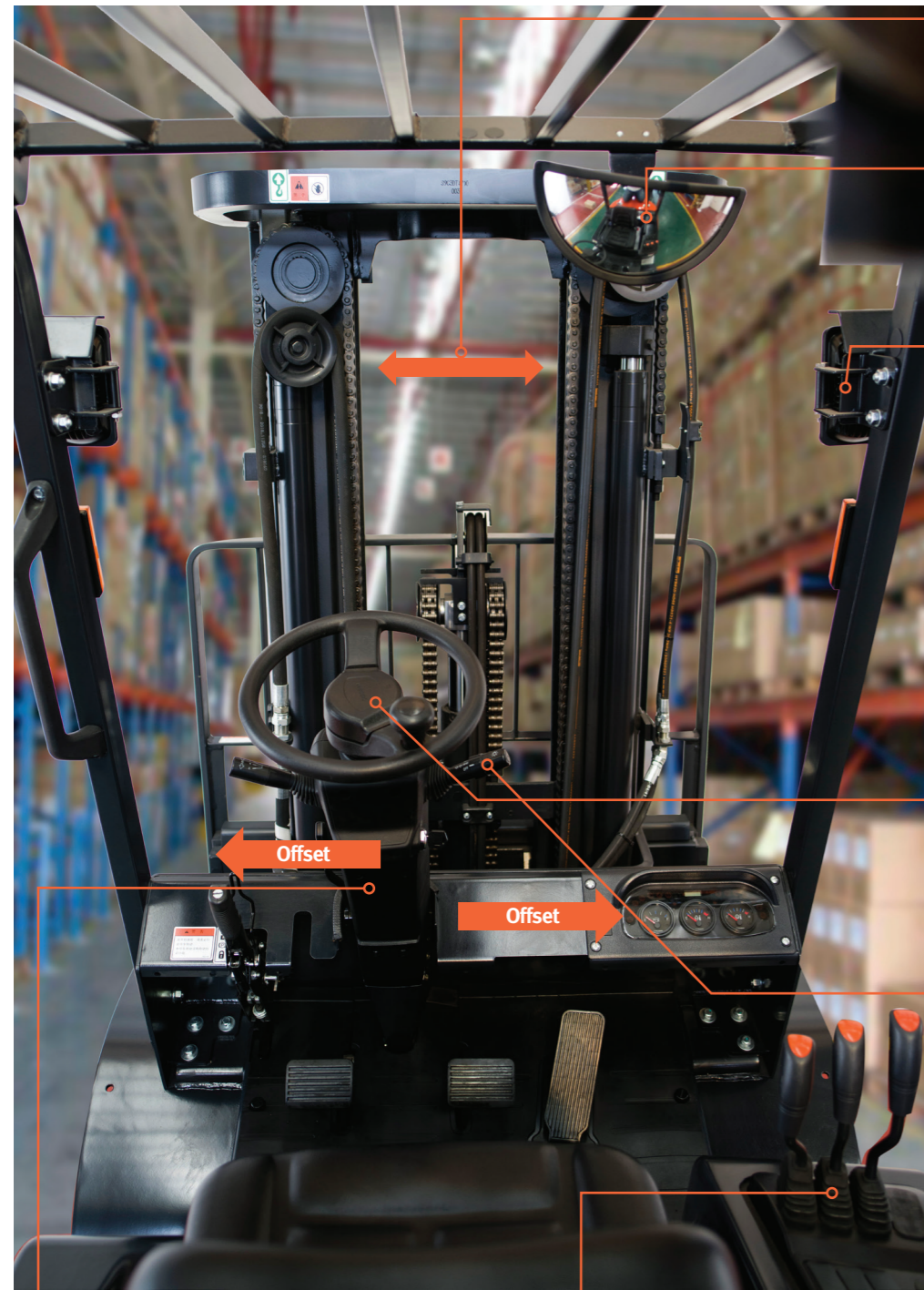

Wide Mast Visibility

Neatly arranged hoses and chains provide wide visibility.

Panoramic Mirror

The panoramic mirror offers wide rear view and greatly improves driving safety.

LED Lamp

Long-lasting, high-brightness LED lights is equipped as standard feature.



Small Steering Wheel

Compact steering wheel offers steering convenience and reduces operator fatigue.



Integrated Lamp Switch

The turn signal and head lamp switches are integrated for convenient operation.

Steering Column & Instrument Panel Offset

Steering column is shifted to the left for more comfortable posture. Instrument panel is also shifted to the right for easier viewing.

Hood Mounted Hydraulic Control Levers

Hood mounted Control levers really reduces operator's fatigue with its comfortable position.

- NX : Cowl mounted
- NXP : Hood mounted



Cowl Height : 40mm



Chamfer



Improved Front / Rear Visibility

The improvement of FCU column height and counter weight design has increased front and rear visibility and enables safer driving.

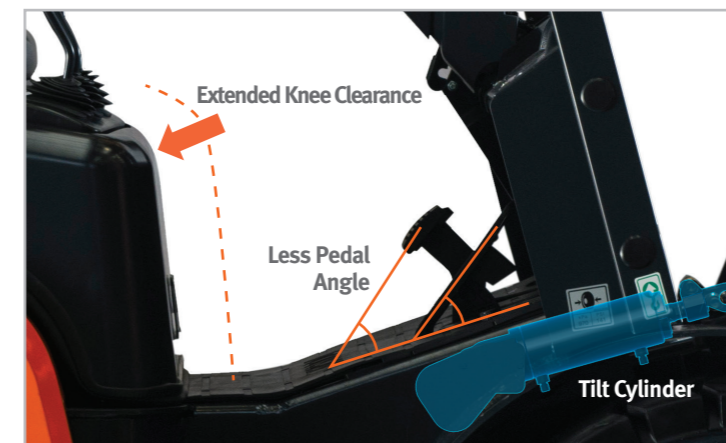

Extended Knee Clearance

Less Pedal Angle

Tilt Cylinder

More Spacious Leg Room

The knee clearance is widened and tilt cylinder is removed on the floor plate, it allows more spacious leg room. Accel and brake pedal clearance and angle are improved to reduce ankle fatigue.

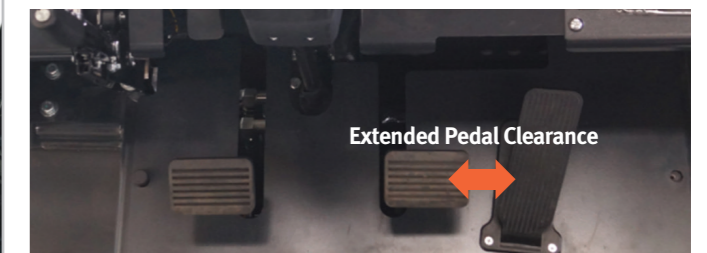

Extended Pedal Clearance



39°

Adjustable Tilt Steering Column

The steering column can be adjusted over a wide range of angles, allowing optimal posture for operator.



Extended Steering Angle

Turning radius is improved by increasing the steering angle. It brings more maneuverability in small space.

Enhanced Safety

NX helps safer operation. NX is equipped with various safety features. It prevents unexpected accidents, ensuring safety of employees.



Large Entry Grip Bar
The entry grip bar is larger, so it is easy to grip and allows safer ride on / off.



Anti-Skid Step Plate
The wider step plate prevents slipping and it also helps safer ride on / off.



Rearranging of Tilt Cylinder
Tilt cylinder is removed on the floor plate, preventing operator from falling over.



AUTO STOP

OSS* (Operator Sensing System)

OSS function avoids any unintended truck movements when the operator is not seated.

- ① Warning when operator leaves the seat without parking brake.
- ② Warning when operator drives without seatbelt fastened.
- ③ Automatically stop the vehicle when operator leaves the seat.



LOCK

ISO3691* Hyd. Locking Valve

If operator leaves or turns-off the truck, this system will automatically lock the hydraulic function, not allowing lifting, tilting, lowering.

*NXP only

Improved Serviceability

NX offers outstanding serviceability. It is designed considering maintenance and can be repaired easier and quicker.



Wide Open Hood Angle
It is easy to access engine room by enlarging the hood open angle.



Junction Box
Fuse and relay are concentrated for easy maintenance.



Removable Side Cover
By applying knob bolt, it can be disassembled by hand.

Hood Locking Cylinder
It helps easy maintenance and prevents safety accident.

Better Serviceability

Worldwide Service Network

- Head quarter
- Overseas offices and service centers



Doosan provides high-quality support, relying on its extensive dealer network. No matter where you are located, highly-skilled professionals are always ready to help you, guaranteeing maximum uptime.



Doosan Genuine Parts

The parts warehouse, supplies high quality Doosan parts to the dealer network.



Main Specifications

| Model Designation | | D20NXP | D25NXP | D30NXP | D33NXP | D35NXP | D20NX | D25NX | D30NX | D33NX | D35NX |
|---|----|--------|--------|--------|--------|--------|-------|-------|-------|-------|-------|
| Load Capacity | kg | 2,000 | 2,500 | 3,000 | 3,300 | 3,500 | 2,000 | 2,500 | 3,000 | 3,300 | 3,500 |
| Load Center | mm | 500 | 500 | 500 | 500 | 500 | 500 | 500 | 500 | 500 | 500 |
| Load Distance, Centre of Drive Axle to Fork | mm | 477 | 477 | 482 | 487 | 487 | 467 | 467 | 472 | 477 | 477 |
| Wheelbase | mm | 1,700 | 1,700 | 1,700 | 1,700 | 1,700 | 1,700 | 1,700 | 1,700 | 1,700 | 1,700 |
| Height, Mast Lowered | mm | 2,045 | 2,045 | 2,045 | 2,045 | 2,045 | 2,045 | 2,045 | 2,045 | 2,045 | 2,045 |
| Free Lift | mm | 150 | 150 | 150 | 150 | 150 | 150 | 150 | 150 | 150 | 150 |
| Lift (with STD 2-Stage Mast) | mm | 3,000 | 3,000 | 3,000 | 3,000 | 3,000 | 3,000 | 3,000 | 3,000 | 3,000 | 3,000 |
| Height, Mast Extended | mm | 4,247 | 4,247 | 4,247 | 4,252 | 4,252 | 4,247 | 4,247 | 4,247 | 4,252 | 4,252 |
| Height of Overhead Guard (Cabin) | mm | 2,160 | 2,160 | 2,160 | 2,160 | 2,160 | 2,160 | 2,160 | 2,160 | 2,160 | 2,160 |
| Height of Seat | mm | 1,185 | 1,185 | 1,185 | 1,185 | 1,185 | 1,185 | 1,185 | 1,185 | 1,185 | 1,185 |
| Overall Length | mm | 3,610 | 3,660 | 3,715 | 3,780 | 3,800 | 3,610 | 3,660 | 3,715 | 3,780 | 3,800 |
| Length to Fork Face | mm | 2,560 | 2,610 | 2,665 | 2,730 | 2,750 | 2,560 | 2,610 | 2,665 | 2,730 | 2,750 |
| Overall Width | mm | 1,290 | 1,290 | 1,290 | 1,290 | 1,290 | 1,290 | 1,290 | 1,290 | 1,290 | 1,290 |
| Turning Radius | mm | 2,280 | 2,330 | 2,415 | 2,460 | 2,480 | 2,275 | 2,325 | 2,410 | 2,455 | 2,475 |

Standard Features and Optional Extras

| Performance | NX (Weichai 3.2L) | NX Plus (Yanmar 3.0L) | NX Plus (Yanmar 3.3L) | NX Premium (Yanmar 3.3L) |
|----------------------------|----------------------------|----------------------------|--------------------------|-----------------------------|
| Engine Manufacturer / Type | Weichai WP 3.2 | YANMAR 4TNE94L | YANMAR 4TNE98 | |
| Emission Regulation | Non-Certi | Stage IIIA or EPA Tier III | | |
| Transmission Type | Power Shift / Manual Shift | Auto Shift | | |
| Aux. Weight | | | | |
| Power Shoe Brakes | | | | |

| Durability | NX (Weichai 3.2L) | NX Plus (Yanmar 3.0L) | NX Plus (Yanmar 3.3L) | NX Premium (Yanmar 3.3L) |
|--------------------------|----------------------|--------------------------|--------------------------|-----------------------------|
| Mast with JJ Beam | | | | |
| Anti Dust Overhead Guard | | | | |
| Dual Element Air Cleaner | | | | |
| Donaldson Air Cleaner | N/A | | | |
| Heavy Duty Radiator | | | | |
| High Speed Fan | | | | |
| Pre Cleaner | | | | |
| Vented Side Panel | | | | |
| Radiator Screen | | | | |
| Autoshift Controller | N/A | | | |

| Operator Comfort | NX (Weichai 3.2L) | NX Plus (Yanmar 3.0L) | NX Plus (Yanmar 3.3L) | NX Premium (Yanmar 3.3L) |
|--|----------------------|--------------------------|--------------------------|-----------------------------|
| Hydraulic Control Levers | Cowl Mounted | | Hood Mounted | |
| Spacious Leg Room / Comfort Pedal Layout | | | | |
| Clear Front / Rear / Mast Visibility | | | | |
| LED Combination Lamps | | | | |
| Small Steering Wheel | | | | |
| Large Entry Grip Bar | | | | |
| Anti-Skid Step Plate | | | | |
| Panoramic Mirror | | | | |
| Integrated Lamp Switch | | | | |
| Adjustable Steering Column | | | | |
| Steering Knob | | | | |
| Modular Cabin - Type A,B,C | | | | |
| Rear Grab Bar with Horn | | | | |
| Quick Disconnect Hose Couplings | | | | |
| Full Cabin with Heater | | | | |
| Fan | | | | |

| Safety | NX (Weichai 3.2L) | NX Plus (Yanmar 3.0L) | NX Plus (Yanmar 3.3L) | NX Premium (Yanmar 3.3L) |
|--------------------------------------|----------------------|--------------------------|--------------------------|-----------------------------|
| Operator Sensing System | N/A | | | |
| Control Valve with Hydraulic Locking | N/A | | | |
| Engine Shut Down | N/A | | | |
| Rear Safety Light | | | | |
| Strobe | | | | |
| Spark Arrester | | | | |

| Serviceability | NX (Weichai 3.2L) | NX Plus (Yanmar 3.0L) | NX Plus (Yanmar 3.3L) | NX Premium (Yanmar 3.3L) |
|-----------------------|----------------------|--------------------------|--------------------------|-----------------------------|
| Wide Hood Open Range | | | | |
| Junction Box | | | | |
| Toolless Side Panel | | | | |
| Hood Locking Cylinder | | | | |

STD 
 OPTION 

About Doosan

Values that drive our future growth

Trust in people is the foundation on which Doosan has built its century of success

Doosan has always put 'People' first for the past 100 years, based on our management philosophies. 'Business is not meant to make profits, but to help people grow.' (Late Too Pyung Park, First Chairman), and continues to spur corporate development with global competitiveness originated from human resources.

Doosan the oldest, but fastest growing company

Doosan has recorded the longest business history since its inauguration in 1896, but has grown at its most rapid pace for the past 10 years.

Doosan-the global Infrastructure Support Business (ISB) company

Doosan has created in excess of 90% of its sales within the ISB sector through vigorous reorganisation of its business portfolio since 1998. In the past, 70% of our business was concentrated on consumer goods, but we have successfully transformed our business DNA to the infrastructure support business that constructs and reinforces social infrastructure.

Doosan, surging as a global company

Doosan has become the global ISB leader based on its world class products and services. In addition, as a true global company, Doosan's overseas employees encompass 50% of its human resources, and overseas sales take more than over 60% of the total sales.



Doosan Infracore - Construction equipment

Committed To Our Customers
We are committed to our customers, providing superior products and excellent services to go with them into the future.



Doosan Heavy - Marine engines

Committed To Innovation
We remain committed to the advancement of new technologies and development of talented individuals, positioning us to respond effectively to the rapid changes taking place in the 21st century. Our mission is to strengthen our global position and become the industry leader well into the future.



Doosan Bobcat - Skid loader (with Doosan engine)



Doosan Way
The Doosan Way is our unique way of doing business; the philosophy and culture that will guide us to become the "Proud Global Doosan."





Our Promise
Doosan will be the partner you can count on, always putting our commitment to you first.



Doosan Heavy - Seawater desalination plants



-  Production Subsidiary
-  Sales Subsidiary
-  Parts Depot Center



Doosan Corporation Industrial Vehicle
Web site: www.doosan-iv.com

2019 July

Authorized Dealer

| |
|--|
| |
|--|